



Sign Permit Application

Community Development Department – Planning Division

125 East College Street • Covina, California 91723 • (626) 384-5450 / Fax: (626) 384-5479

Please complete all applicable sections of this application for approval.

Sign Permit Procedure:

1. Fill out application for Sign Permit
2. Include requested attachments as listed on the bottom of page 2;
3. Pay the applicable Sign Permit fee: (**\$316.00 – Permanent Signage or \$105.00 – Temporary Banner**)
4. When the Sign Permit is approved by the Planning Division you will be called for pick-up; and
5. You will then submit two sets (stamped by Planning) to the Building Safety Division for their review and Building Permit issuance (keep in mind Building safety Division will NOT accept applications without Planning Division’s approval first).

| Applicant Information | | STAFF USE ONLY FILE / MUNIS NO: |
|-----------------------|---------|--|
| Name: | | |
| Address: | | |
| City and Zip Code: | | |
| Phone: () | E-Mail: | |

| Contact Information (if different from above) | |
|---|--------|
| Name: | |
| Address: | |
| City and Zip Code: | |
| Phone () | Email: |

| Project Information | |
|--|--|
| Project Address: | |
| How many stories is the subject building? | How tall is the subject building? (<i>In feet</i>) |
| Is the sign located on a multi-tenant building? (Yes or No) | |
| Does your Commerical Center have a Master Sign Program? (Yes or No) | |
| <i>If so, you are required to obtained signage approval from the property manager. This can be done in the form of an attached letter or authorized signature on a copy of the sign plans.</i> | |
| Name of Master Sign Program: (if applicable) | |

Project Description:

| Type of Signs (please check all that apply) | | |
|--|---|---|
| <input type="checkbox"/> Wall Sign | <input type="checkbox"/> Window Signage | <input type="checkbox"/> Electronic Message |
| <input type="checkbox"/> Changeable Copy (Face Change) | <input type="checkbox"/> Free-standing | <input type="checkbox"/> Temporary Banner |
| <input type="checkbox"/> Directional | <input type="checkbox"/> Monument Sign | <input type="checkbox"/> Temporary Signage (COVID-19) |
| <input type="checkbox"/> Canopy | <input type="checkbox"/> _____ (Other) | <input type="checkbox"/> _____ (Other) |

| Proposed Signage | | | | | |
|------------------|-----------|----------------------------|----------------------------|-------------------------------------|-------------------------|
| No. | Sign Type | Illuminated (Yes or No) | Sign Dimensions (W x H) | Total Sign Area (in square feet) | Length of Storefront |
| | | | | | |
| | | | | | |
| | | | | | |
| | | | | | |

Supplemental Requirements

Three (3) scaled sets of:

1. Color copies of **Elevations**, showing sign materials, the building and exact location of sign(s) (proposed and existing); dimensions, materials, illumination, color, and finishes; building frontage (in feet); and background area (in square feet), and architectural features. If a freestanding or monument sign, show maximum height, sign thickness, and sign dimensions.
2. **Drawn Sections**.
3. **Site Plan**, which includes property lines, adjacent streets, and exact location of the sign(s).
4. Additional information/materials may be required based on type of sign(s)/circumstances.

| STAFF USE ONLY | | | |
|--|--------------|-------|-------------|
| Date Received: | Received by: | Fees: | Receipt No: |
| | | | |
| FORMULA: | | | |
| _____ (Occupancy frontage) X 16 ft (Always 1-story) = _____ X .15 (15% of 1 st story height of bldg.) | | | |
| = _____ X .8 (80% of sign area) = _____ (Max. signage allowed) | | | |



Community Development Department

– Planning Division

125 East College Street • Covina, California
91723 • (626) 384-5450 / Fax: (626) 384-5479

GENERAL NOTES FOR COVINA SIGN PERMIT DETAIL REQUIREMENTS

This handout shows the type of details needed to receive a sign permit from the City of Covina. Not all details will be required of each application. Also, the handout does not show all types of signage the City allows. For complete sign standards and detail requirements, check with the Covina Planning and Building Divisions. All Planning Division standards and design criteria are based on the City Code, Design Guidelines, and Downtown Specific Plan, when applicable. (For example, the Downtown Specific Plan area has unique sign guidelines.) In addition, note that some new commercial properties and the Village Oaks Business Park have comprehensive sign programs, which either partly or entirely supersede the general sign standards. In such cases, the approval by the property's owner or manager may be required prior to city staff approval. (New major commercial and industrial complexes must go through a sign program process.) It should be noted that what the city considers a non-conforming sign cannot be altered or enlarged, though standard copy changes are permitted.

Submit three (3) complete sets of drawings for any permit application. Size of sheets should be at least 11"x17" but may be smaller if project is minor. See Planning Division for clarification.

NOTES:

1. Draw to scale exactly what sign will look like. All dimensions must be complete.
2. Generally, one (1) sign permitted per occupancy frontage (portion of tenant space that faces street or parking area).
3. Sign design and colors to be attractive and consistent with Design Guidelines.
4. Maximum permitted cabinet or channel letter sign and street setbacks are as illustrated on following page of this handout.
5. Maximum permitted copy area of cabinet sign (portion denoted to words, symbols, etc.) is 40% of cabinet. Refer to drawings for classification.
6. Maximum permitted channel letter sign size is determined by following same procedures for cabinet signs as stated above and then multiplying number by .80. Again, Design Guidelines limit the letter height based on the business size and street setback.
7. Total sign area refers to aggregate surface space of sign – or the product of the width and height. For cabinets, this refers to the cabinet dimensions; for channel letter signs, the number is combined area of all words and symbols.
8. For face changes only, existing cabinets general can remain, but new faces must comply with 40% copy rule and other design requirements.

1. BUILDING FACE SIGNS:

A. CABINET/CAN TYPE

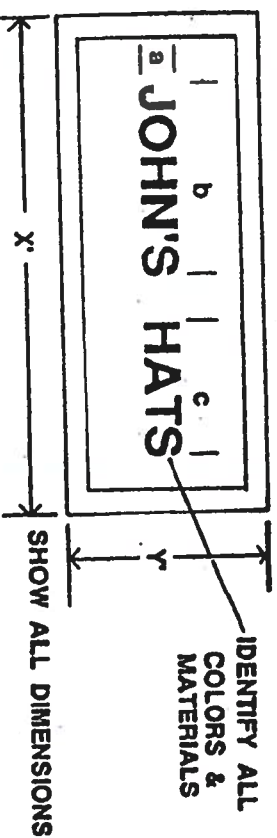

**COPY AREA = a (b + c)
MUST BE NO GREATER
THAN .40 (X x Y)**

B. CHANNEL LETTER SIGNS

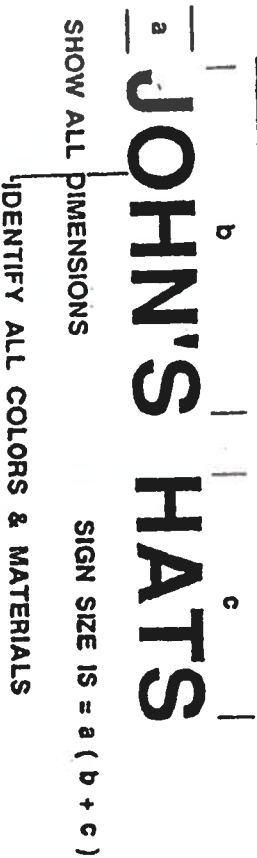

SIGN SIZE IS = a (b + c)

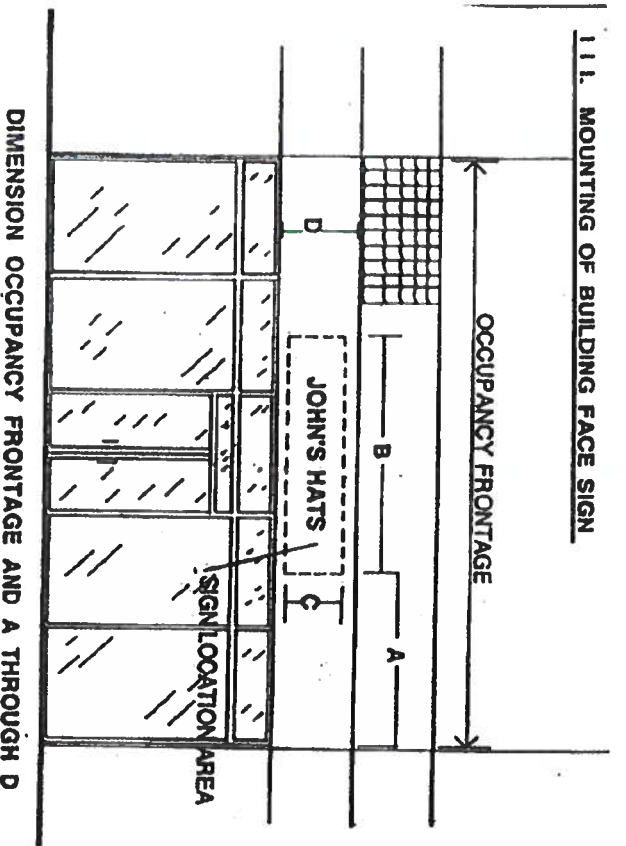

DIMENSION OCCUPANCY FRONTAGE AND A THROUGH D

NOTES:

1. Draw to scale general drawings of applicable occupancy frontage (front and side, if necessary) and where sign is to be mounted.
2. Signs must be mounted flush against building below roof line, and in appropriate area or centered. Where building conditions warrant some signs, subject to City approval, may be placed in another area.
3. If appropriate and acceptable to planning, building face sign details (previous page) can be illustrated at sign location area, and not all of occupancy frontage need be shown.

1 V. MOUNTING DETAILS

EXPLANATORY NOTES ON:

1. CABINET OR LETTER CONSTRUCTION & MOUNTING
2. ILLUMINATION
3. FACE(S)
4. ELECTRICAL CONNECTIONS
5. OTHER

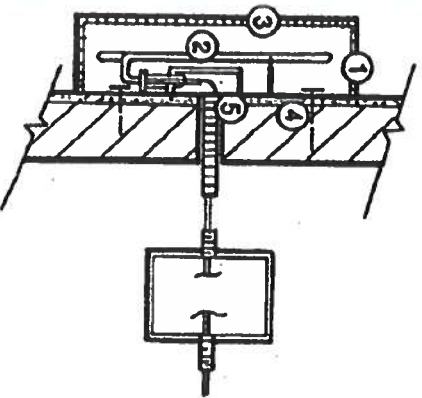

NOTES:

1. Show how sign will be mounted / connected to building.
2. For clarification, on structural and electrical details and notes, see Building Division.
3. No details required for face change.

V. FREESTANDING SIGNS

A. GENERAL FREESTANDING / POLE SIGN

LIST ALL COLORS



**FOR BOTH SIGNS
SHOW ALL DIMENSIONS.**

**THE 40% COPY
AREA MAXIMUM**

REQUIREMENT APPLIES.

B. MONUMENT SIGN

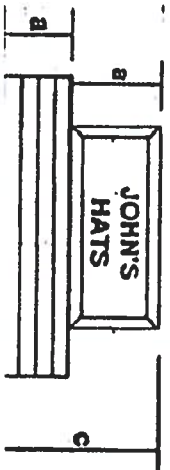

NOTES:

1. Draw to scale, including copy material, exactly what sign will look like. All dimensions must be complete.
2. One or two freestanding signs may be permitted. Refer to Covina Code for determination.
3. Design to be attractive, harmonious with building(s) on property, and consistent with Design Guidelines. Where pole signs area permitted, monument signs are preferred.
4. Refer to Covina Code for maximum sign area height, which is measured from top of sign to the average surface grade immediately surrounding the base. (Top of sign includes structural elements, but does not include features determined by the staff to be ornamental / decorative).
5. The sign area refers to the total aggregate surface space of the sign, excluding the height of any pole or base. See accompanying drawings for clarification.
6. Maximum permitted copy area of either sign (portion devoted to words, symbols, etc.) is 40% of cabinet size.
7. For face changes only, existing cabinets generally can remain but new faces must comply with 40% copy rule and all other requirements.
8. Structural and electrical details shall also be submitted. See Building Division for details.

NOTES:

1. Does not have to be drawn to exact scale, but must show general site layouts and where monument sign and other signs are to be located. (The entire site may not have to be drawn. Consult with Planning for clarification.)
2. The dripline of any freestanding sign shall be setback at least 5 feet or maximum distance feasible from property line.
3. The sign generally shall be located in a landscaped area.
4. No portion of the sign can be situated within 10 feet of any driveway or in any other location where the line of sight for drive or pedestrians could be obstructed.

V. I. SIGN LOCATION PLAN

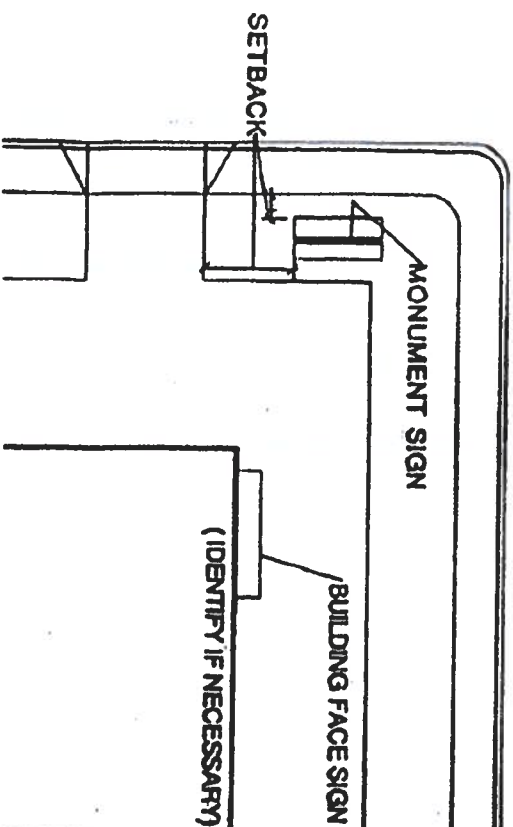

**MAXIMUM HEIGHT FOR BOX-TYPE CAN SIGNS (CAN) AND
INDIVIDUAL CHANNEL LETTER SIGNS (I.C.L.)**

| DISTANCE FROM SIGN TO RIGHT- OF-WAY | BUSINESS BELOW 2,000 SQ. FT. IN AREA | | BUSINESS FROM 2,000 – 8,000 SQ. FT. IN AREA | | | | | |
|---|--|--------|---|--------|----------------|--------|---------|--------|
| | | | 8,000 | | 8,000 – 20,000 | | +20,000 | |
| | CAN | I.C.L. | CAN | I.C.L. | CAN | I.C.L. | CAN | I.C.L. |
| 50' | 24" | 16" | 30" | 20" | 36" | 24" | 45" | 30" |
| 50'-100' | 27" | 18" | 33" | 22" | 39" | 26" | 48" | 34" |
| 100'-200' | 30" | 20" | 36" | 24" | 42" | 30" | 48" | 36" |
| 200'-400' | 36" | 24" | 45" | 30" | 48" | 36" | 48" | 48" |
| 400'-700' | 36" | 24" | 48" | 36" | 48" | 36" | 48" | 54" |
| 700' – | 36" | 24" | 48" | 40" | 48" | 36" | 48" | 60" |