



CHECKLIST FOR SIGN PROGRAM

Community Development Department – Planning Division
125 East College Street • Covina, California 91723 • (626) 384-5450

Sign Program Checklist

The items listed below are considered a minimum. Additional information may be necessary for clarification during the review process. Submit a complete standard application form, 2 sets of plans and sign program and sign program fee.

- A. Building Wall Signs:
 - 1. Detailed Site Plan, drawn to scale, shall include the following:
 - Project site area including dimensioned property lines
 - All site improvements including, but not limited to, buildings, parking areas, driveways, etc.
 - Shade the building where the proposed building signs are to be located
 - 2. Building Elevations:
 - Accurate building elevations showing building face with dimensions
 - Exact location and placement of the proposed signs
 - 3. Detailed Elevations of Signs:
 - Dimensions of proposed signs
 - Depth of signs (thickness)
 - Letter style, size, materials, and colors of sign copy
 - Method of illumination
- B. Monument Sign:
 - 1. Detailed Site Plan, drawn to scale, shall include the following:
 - Location of proposed monument sign, including setback dimension from curb face and other monument signs
 - Project site area including dimensioned property lines
 - All site improvements including, but not limited to, buildings, parking areas, driveways, etc.
 - Public street frontages and improvements
 - Proposed landscaping and irrigation system around the monument sign
 - 2. Detailed Elevations of monument sign:
 - Dimensions of the proposed sign and the base
 - Depth of signs (cross sections)
 - Letter style, size, materials, and colors of sign copy and the background
 - Full base description including materials, colors, and height
 - Landscape materials around the base of the sign
 - Method of illumination
- C. Menu Board(s) and/or Directional Sign(s) for Drive-Through Facilities:
 - Sign locations
 - Sizes (maximum sign area, minimum and maximum letter height)
 - Colors (including color number)
 - Materials
 - Illumination



CHECKLIST FOR SIGN PROGRAM

Community Development Department – Planning Division
125 East College Street • Covina, California 91723 • (626) 384-5450

- C. Written sign criteria:
 Tenant category definitions (major, sub-major, shop tenant, pad tenant)
 - Sign locations.
 - Sizes (maximum sign area, minimum and maximum letter height)
 - Colors (including color number)
 - Materials
 - Illumination
 - Other additional information
 - Lettering style(s) (type, lower and/or upper case)
 - Major tenants' sign criteria
 - Graphic logo criteria

- D. Summary of sign criteria in the table format as shown in the below and to be included in the Sign Program

Sign Program No. _____

Summary of Sign Criteria

	Shop Tenants sq. ft. ()	Sub-major Tenants sq. ft. ()	Major Tenants over () sq. ft.
Sign Width			
Sign Height			
Sign Area			
Colors			
Logo (Graphics)			
Sign Style			
No. of Signs			

Dimension the width and height for the graphic logo and the sign letters and the total sign copy (graphic logo and letters)

SHOW SAMPLE OF
GRAPHIC LOGO

SHOW SAMPLE OF SIGN COPY IN LETTERS



Sign Permit Application (Sign Program)

Community Development Department – Planning Division

125 East College Street • Covina, California 91723 • (626) 384-5450 / Fax: (626) 384-5479

Please complete all applicable sections of this application for approval.

Sign Permit Procedure:

1. Fill out application for Sign Permit
2. Include requested attachments as listed on the bottom of page 2;
3. Pay the applicable Sign Permit fee: **(\$316.00 – Permanent Signage or \$105.00 – Temporary Banner)**
4. When the Sign Permit is approved by the Planning Division you will be called for pick-up; and
5. You will then submit two sets (stamped by Planning) to the Building Safety Division for their review and Building Permit issuance (keep in mind Building safety Division will NOT accept applications without Planning Division’s approval first).

Applicant Information	
Name:	STAFF USE ONLY FILE / MUNIS NO:
Address:	
City and Zip Code:	
Phone: () E-Mail:	

Contact Information (if different from above)	
Name:	
Address:	
City and Zip Code:	
Phone () Email:	

Project Information	
Project Address:	
How many stories is the subject building?	How tall is the subject building? <i>(In feet)</i>
Is the sign located on a multi-tenant building? (Yes or No)	
Does your Commerical Center have a Master Sign Program? (Yes or No)	
<i>If so, you are required to obtained signage approval from the property manager. This can be done in the form of an attached letter or authorized signature on a copy of the sign plans.</i>	
Name of Master Sign Program: (if applicable)	

Project Description:

Type of Signs (please check all that apply)		
<input type="checkbox"/> Wall Sign	<input type="checkbox"/> Window Signage	<input type="checkbox"/> Electronic Message
<input type="checkbox"/> Changeable Copy (Face Change)	<input type="checkbox"/> Free-standing	<input type="checkbox"/> Temporary Banner
<input type="checkbox"/> Directional	<input type="checkbox"/> Monument Sign	<input type="checkbox"/> Temporary Signage (COVID-19)
<input type="checkbox"/> Canopy	<input type="checkbox"/> _____ (Other)	<input type="checkbox"/> _____ (Other)

Proposed Signage					
No.	Sign Type	Illuminated (Yes or No)	Sign Dimensions (W x H)	Total Sign Area (in square feet)	Length of Storefront

Supplemental Requirements

Three (3) scaled sets of:

1. Color copies of **Elevations**, showing sign materials, the building and exact location of sign(s) (proposed and existing); dimensions, materials, illumination, color, and finishes; building frontage (in feet); and background area (in square feet), and architectural features. If a freestanding or monument sign, show maximum height, sign thickness, and sign dimensions.
2. **Drawn Sections**.
3. **Site Plan**, which includes property lines, adjacent streets, and exact location of the sign(s).
4. Additional information/materials may be required based on type of sign(s)/circumstances.

STAFF USE ONLY			
Date Received:	Received by:	Fees:	Receipt No:
FORMULA:			
_____ (Occupancy frontage) X 16 ft (Always 1-story) = _____ X .15 (15% of 1 st story height of bldg.)			
= _____ X .8 (80% of sign area) = _____ (Max. signage allowed)			



Community Development Department

- Planning Division

125 East College Street • Covina, California
 91723 • (626) 384-5450 / Fax: (626) 384-5479

GENERAL NOTES FOR COVINA SIGN PERMIT DETAIL REQUIREMENTS

This handout shows the type of details needed to receive a sign permit from the City of Covina. Not all details will be required of each application. Also, the handout does not show all types of signage the City allows. For complete sign standards and detail requirements, check with the Covina Planning and Building Divisions. All Planning Division standards and design criteria are based on the City Code, Design Guidelines, and Downtown Specific Plan, when applicable. (For example, the Downtown Specific Plan area has unique sign guidelines.) In addition, note that some new commercial properties and the Village Oaks Business Park have comprehensive sign programs, which either partly or entirely supersede the general sign standards. In such cases, the approval by the property's owner or manager may be required prior to city staff approval. (New major commercial and industrial complexes must go through a sign program process.) It should be noted that what the city considers a non-conforming sign cannot be altered or enlarged, though standard copy changes are permitted.

Submit three (3) complete sets of drawings for any permit application. Size of sheets should be at least 11"x17" but may be smaller if project is minor. See Planning Division for clarification.

NOTES:

1. Draw to scale exactly what sign will look like. All dimensions must be complete.
2. Generally, one (1) sign permitted per occupancy frontage (portion of tenant space that faces street or parking area).
3. Sign design and colors to be attractive and consistent with Design Guidelines.
4. Maximum permitted cabinet or channel letter sign and street setbacks are as illustrated on following page of this handout.
5. Maximum permitted copy area of cabinet sign (portion denoted to words symbols, etc.) is 40% of cabinet. Refer to drawings for classification.
6. Maximum permitted channel letter sign size is determined by following same procedures for cabinet signs as stated above and then multiplying number by .80. Again, Design Guidelines limit the letter height based on the business size and street setback.
7. Total sign area refers to aggregate surface space of sign - or the product of the width and height. For cabinets, this refers to the cabinet dimensions; for channel letter signs, the number is combined area of all words and symbols.
8. For face changes only, existing cabinets general can remain, but new faces must comply with 40% copy rule and other design requirements.

I. BUILDING FACE SIGNS:

A. CABINET/CAN TYPE

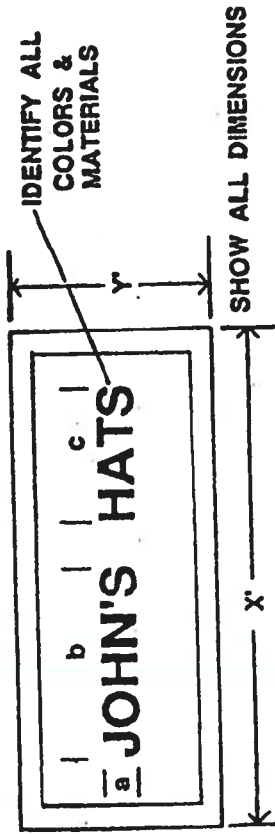

B. CHANNEL LETTER SIGNS

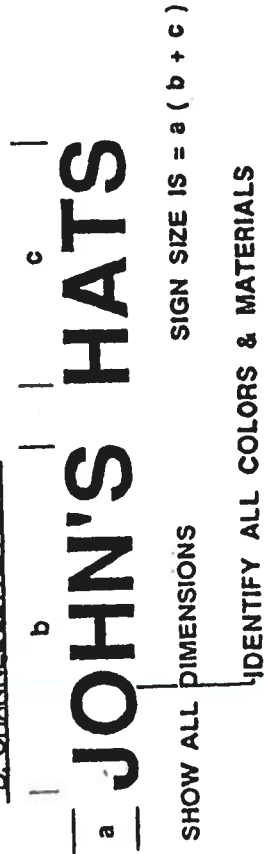

1.1.1. MOUNTING OF BUILDING FACE SIGN

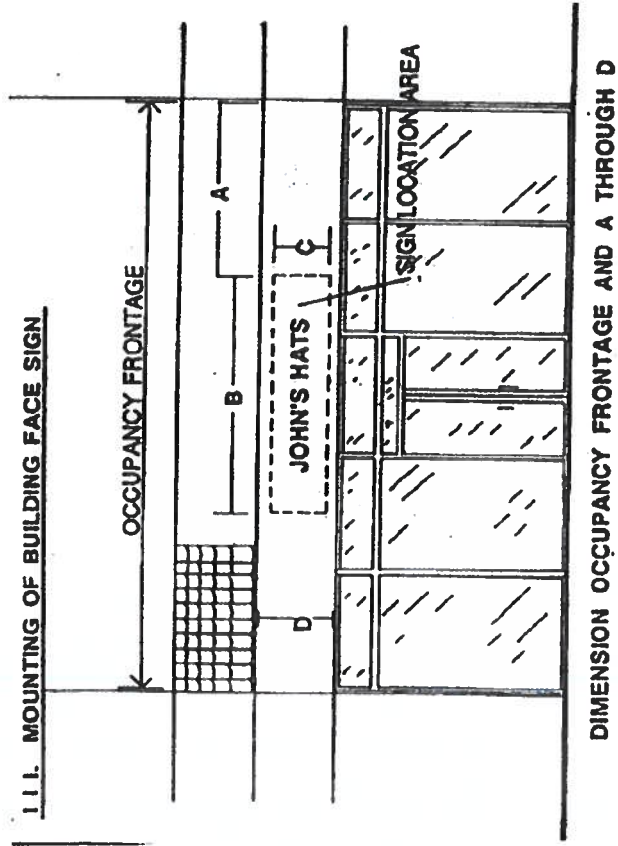

DIMENSION OCCUPANCY FRONTAGE AND A THROUGH D

NOTES:

1. Draw to scale general drawings of applicable occupancy frontage (front and side, if necessary) and where sign is to be mounted.
2. Signs must be mounted flush against building below roof line, and in appropriate area or centered. Where building conditions warrant some signs, subject to City approval, may be placed in another area.
3. If appropriate and acceptable to planning, building face sign details (previous page) can be illustrated at sign location area, and not all of occupancy frontage need be shown.

1. V. MOUNTING DETAILS

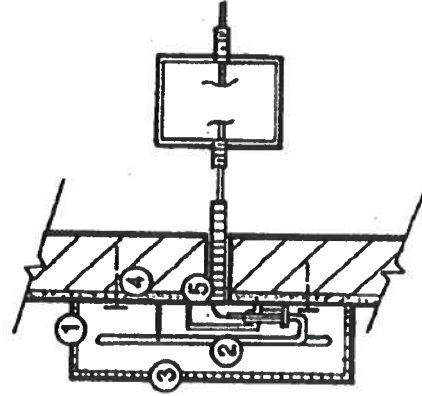

EXPLANATORY NOTES ON:

1. CABINET OR LETTER
2. CONSTRUCTION & MOUNTING
3. ILLUMINATION
3. FACE(S)
4. ELECTRICAL CONNECTIONS
5. OTHER

NOTES:

1. Show how sign will be mounted / connected to building.
2. For clarification, on structural and electrical details and notes, see Building Division.
3. No details required for face change.

V. FREESTANDING SIGNS

A. GENERAL FREESTANDING/POLE SIGN

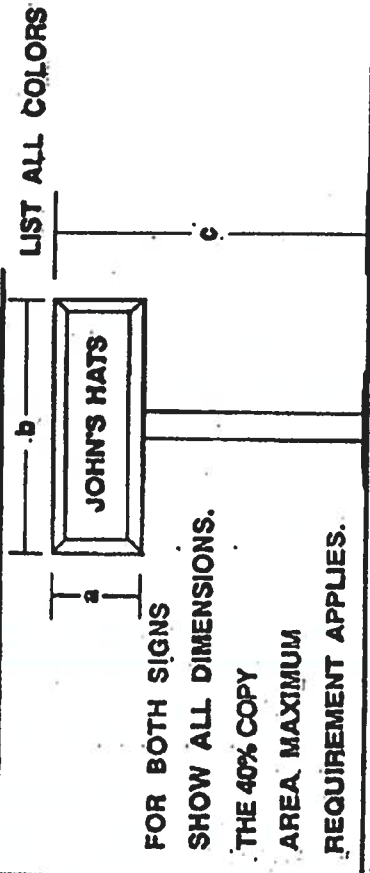

B. MONUMENT SIGN

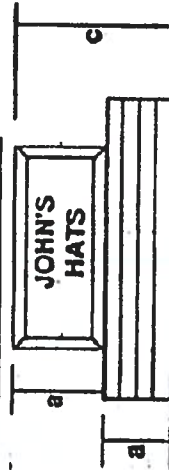

NOTES:

1. Draw to scale, including copy material, exactly what sign will look like. All dimensions must be complete.
2. One or two freestanding signs may be permitted. Refer to Covina Code for determination.
3. Design to be attractive, harmonious with building(s) on property, and consistent with Design Guidelines. Where pole signs area permitted, monument signs are preferred.
4. Refer to Covina Code for maximum sign area height, which is measured from top of sign to the average surface grade immediately surrounding the base. (Top of sign includes structural elements, but does not include features determined by the staff to be ornamental / decorative).
5. The sign area refers to the total aggregate surface space of the sign, excluding the height of any pole or base. See accompanying drawings for clarification.
6. Maximum permitted copy area of either sign (portion devoted to words, symbols, etc.) is 40% of cabinet size.
7. For face changes only, existing cabinets generally can remain but new faces must comply with 40% copy rule and all other requirements.
8. Structural and electrical details shall also be submitted. See Building Division for details.

V I. SIGN LOCATION PLAN

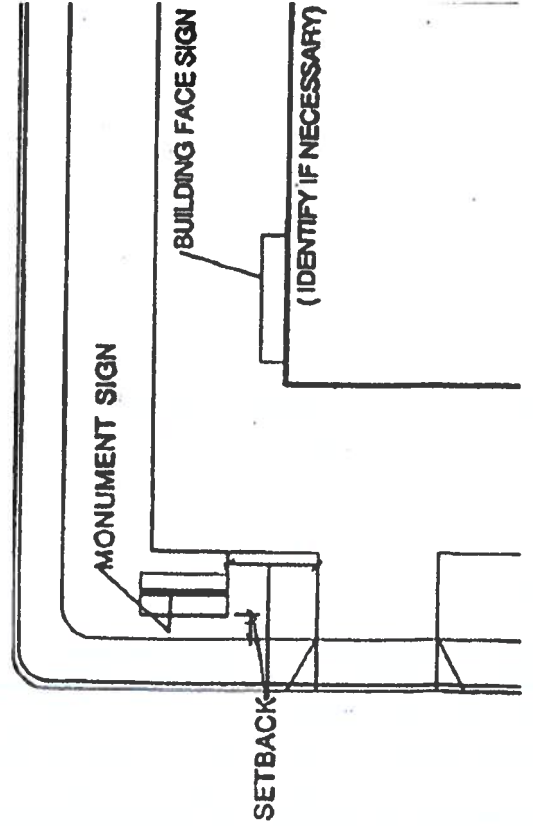

NOTES:

1. Does not have to be drawn to exact scale, but must show general site layouts and where monument sign and other signs are to be located. (The entire site may not have to be drawn. Consult with Planning for clarification.)
2. The dripline of any freestanding sign shall be setback at least 5 feet or maximum distance feasible from property line.
3. The sign generally shall be located in a landscaped area.
4. No portion of the sign can be situated within 10 feet of any driveway or in any other location where the line of sight for drive or pedestrians could be obstructed.

**MAXIMUM HEIGHT FOR BOX-TYPE CAN SIGNS (CAN) AND
INDIVIDUAL CHANNEL LETTER SIGNS (I.C.L.)**

DISTANCE FROM SIGN TO RIGHT- OF-WAY	BUSINESS FROM 2,000 – 8,000 SQ. FT. IN AREA							
	BUSINESS BELOW 2,000 SQ. FT. IN AREA		8,000		8,000 – 20,000		+20,000	
	<u>CAN</u>	<u>I.C.L.</u>	<u>CAN</u>	<u>I.C.L.</u>	<u>CAN</u>	<u>I.C.L.</u>	<u>CAN</u>	<u>I.C.L.</u>
50'	24"	16"	30"	20"	36"	24"	45"	30"
50'-100'	27"	18"	33"	22"	39"	26"	48"	34"
100'-200'	30"	20"	36"	24"	42"	30"	48"	36"
200'-400'	36"	24"	45"	30"	48"	36"	48"	48"
400'-700'	36"	24"	48"	36"	48"	36"	48"	54"
700' –	36"	24"	48"	40"	48"	36"	48"	60"